

Dimensions: mm (in)

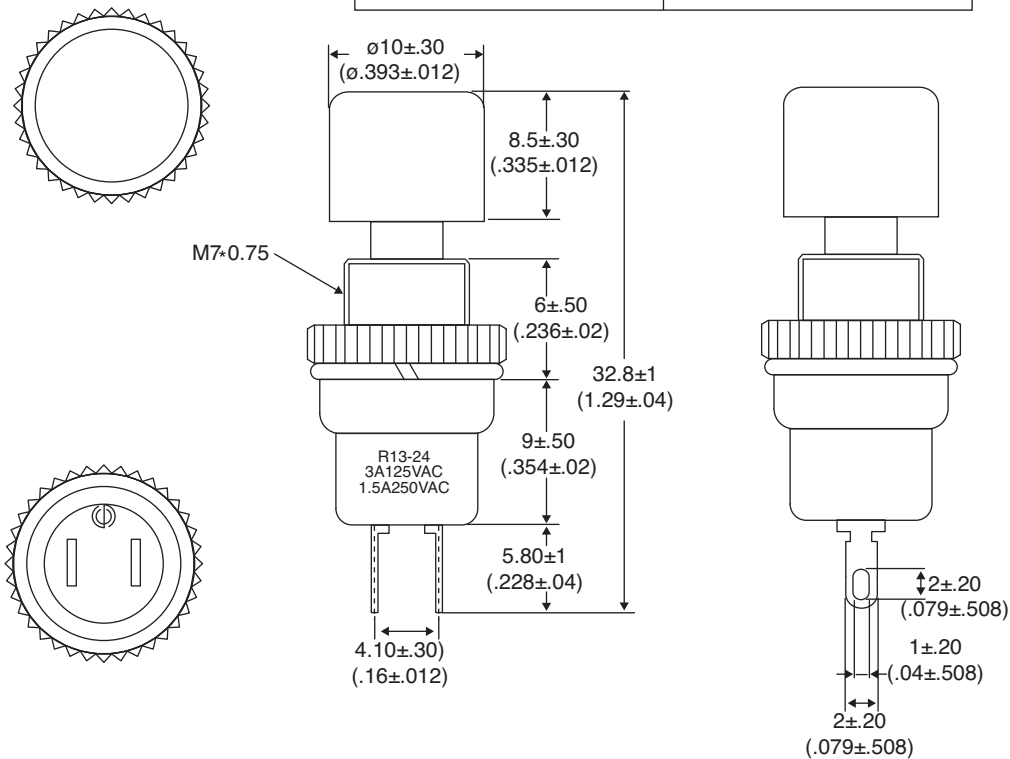
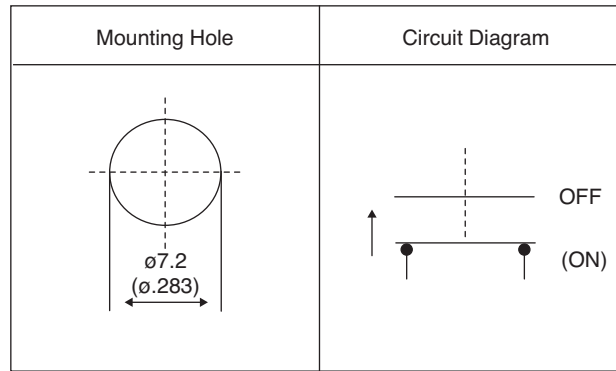

**Electrical Specifications:**

- Rating: 3A/125VAC, 1.5A/250VAC
- Contact resistance: 50mΩ max
- Insulation resistance: 500VDC 100MΩ min
- Dielectric strength: 1500VAC for 1 minute

**Mechanical Specifications:**

- Circuit: 2P SPST off-(on)

**Materials:**

- Button: ABS, B lack
- Slider: ABS, White
- 1 KNURL NUT ASSY
- 1 SPRING WASHER ASSY

**Note:**

- RoHS Compliant by Exemption

MOUSER STOCK NO.	Button Color
103-1022-EVX	Red
103-1023-EVX	Black

**Pushbutton Switches**  
103-1022-EVX, 103-1023-EVX

